

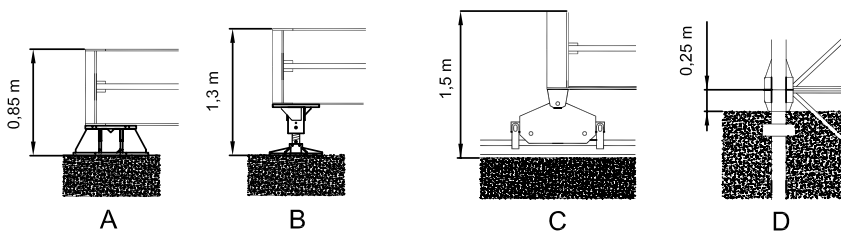

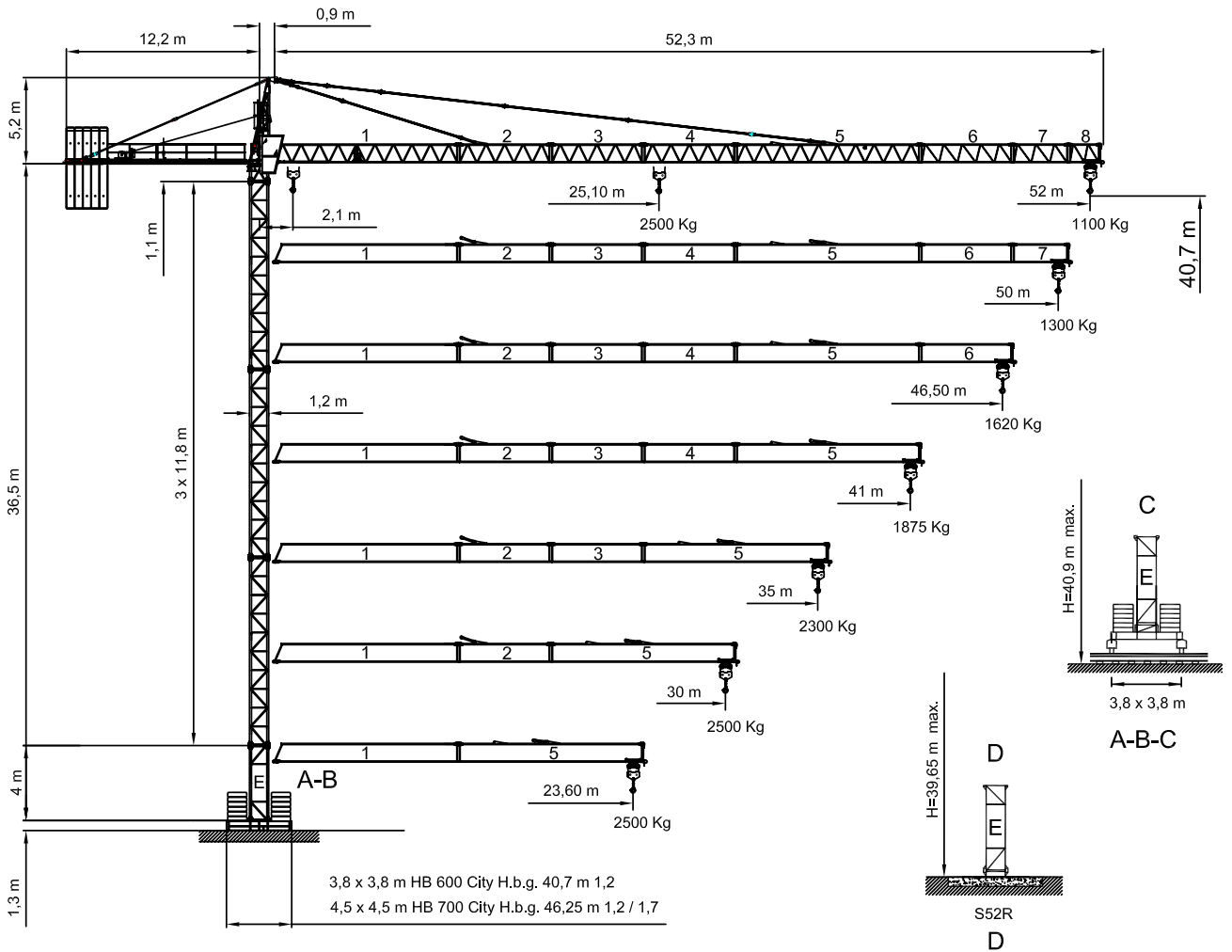

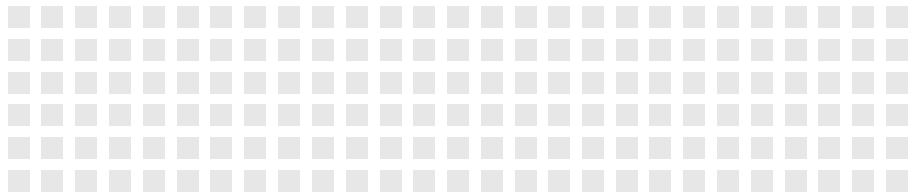























S52 4T









Curvas de cargas- Load diagrams- Lastkurven- Courbes de charges- Curve di carico

| | | | | | | | | | | | | | | | | | | | | |
|--|------|------|------|------|---|------|------|------|---|------|---|---|---|------|---|------|---|------|---|---|
| 52 m  | 18 | 20 | 23,6 | 24 | 25,1 | 26 | 28 | 30 | 33 | 35 | 37 | 39 | 41 | 44 | 46,5 | 48 | 50 | 52 | m |  |
| | 2500 | 2500 | 2500 | 2500 | 2500 | 2400 | 2215 | 2055 | 1850 | 1730 | 1625 | 1535 | 1450 | 1335 | 1270 | 1210 | 1150 | 1100 | Kg |  |
| | 9 | 12 | 15 | 15,5 | 18 | 21 | 23,6 | 27 | 30 | 33 | 35 | 38 | 41 | 44 | 46,5 | 48 | 50 | 52 | m |  |
| | 4000 | 4000 | 4000 | 4000 | 3400 | 2870 | 2590 | 2160 | 1900 | 1700 | 1580 | 1430 | 1300 | 1190 | 1120 | 1060 | 1000 | 950 | Kg | |
| 50 m  | 18 | 20 | 23,6 | 24 | 26 | 27,8 | 28 | 30 | 33 | 35 | 37 | 39 | 41 | 44 | 46,5 | 48 | 50 | m |  | |
| | 2500 | 2500 | 2500 | 2500 | 2500 | 2500 | 2480 | 2300 | 2075 | 1945 | 1825 | 1725 | 1630 | 1505 | 1430 | 1365 | 1300 | Kg |  | |
| | 9 | 12 | 15 | 17,2 | 18 | 21 | 23,6 | 27 | 30 | 33 | 35 | 38 | 41 | 44 | 46,5 | 48 | 50 | m |  | |
| | 4000 | 4000 | 4000 | 4000 | 3815 | 3220 | 2900 | 2430 | 2150 | 1925 | 1795 | 1625 | 1480 | 1355 | 1280 | 1215 | 1150 | Kg | | |
| 46.5 m  | 18 | 20 | 23,6 | 24 | 26 | 28 | 30 | 31,1 | 33 | 35 | 37 | 39 | 41 | 44 | 46,5 | m |  | | | |
| | 2500 | 2500 | 2500 | 2500 | 2500 | 2500 | 2500 | 2500 | 2335 | 2190 | 2065 | 1945 | 1840 | 1705 | 1620 | Kg |  | | | |
| | 9 | 12 | 15 | 18 | 19,2 | 21 | 23,6 | 27 | 30 | 33 | 35 | 38 | 41 | 44 | 46,5 | m |  | | | |
| | 4000 | 4000 | 4000 | 4000 | 4000 | 3635 | 3290 | 2750 | 2440 | 2190 | 2040 | 1850 | 1690 | 1555 | 1470 | Kg | | | | |
| 41 m  | 18 | 20 | 23,6 | 24 | 26 | 28 | 30 | 31,5 | 33 | 35 | 37 | 39 | 41 | m |  | | | | | |
| | 2500 | 2500 | 2500 | 2500 | 2500 | 2500 | 2500 | 2500 | 2380 | 2230 | 2100 | 1980 | 1875 | Kg |  | | | | | |
| | 9 | 12 | 15 | 18 | 19,5 | 21 | 23,6 | 27 | 30 | 33 | 35 | 38 | 41 | m |  | | | | | |
| | 4000 | 4000 | 4000 | 4000 | 4000 | 3700 | 3350 | 2800 | 2490 | 2230 | 2080 | 1890 | 1725 | Kg | | | | | | |
| 35 m  | 18 | 20 | 23,6 | 24 | 26 | 28 | 30 | 32,4 | 33 | 35 | m |  | | | | | | | | |
| | 2500 | 2500 | 2500 | 2500 | 2500 | 2500 | 2500 | 2500 | 2450 | 2300 | Kg |  | | | | | | | | |
| | 9 | 12 | 15 | 18 | 20,1 | 21 | 23,6 | 27 | 30 | 33 | 35 | m |  | | | | | | | |
| | 4000 | 4000 | 4000 | 4000 | 4000 | 3815 | 3450 | 2890 | 2570 | 2300 | 2150 | Kg | | | | | | | | |
| 30 m  | 18 | 20 | 23,6 | 24 | 26 | 28 | 30 | m |  | | | | | | | | | | | |
| | 2500 | 2500 | 2500 | 2500 | 2500 | 2500 | 2500 | Kg |  | | | | | | | | | | | |
| | 9 | 12 | 15 | 18 | 19,6 | 21 | 23,6 | 27 | 30 | m |  | | | | | | | | | |
| | 4000 | 4000 | 4000 | 4000 | 3720 | 3360 | 2815 | 2500 | Kg | | | | | | | | | | | |
| 23.6 m  | 18 | 20 | 23,6 | m |  | | | | | | | | | | | | | | | |
| | 2500 | 2500 | 2500 | Kg |  | | | | | | | | | | | | | | | |
| | 9 | 12 | 15 | 18 | 18,1 | 21 | 23,6 | m |  | | | | | | | | | | | |
| | 4000 | 4000 | 4000 | 4000 | 3415 | 3000 | Kg | | | | | | | | | | | | | |





Bloque de contrapeso- Counterweight blocks- Gegengewichtsblöcke- Bloc de contrepoid- Blocco di contrappeso

| | | | | | | | | | | | | |
|---|----------|---|---|----------|---|---|----------|---|---|----------|---|---|
|  | 52 m | | | 50 m | | | 46,5 m | | | 41 m | | |
|  | A | B | C | A | B | C | A | B | C | A | B | C |
| | 5 | - | - | 5 | - | - | 5 | - | - | 4 | - | 1 |
| | 11500 Kg | | | 11500 Kg | | | 11500 Kg | | | 10050 Kg | | |
|  | 35 m | | | 30 m | | | 23,6 m | | | | | |
|  | A | B | C | A | B | C | A | B | C | | | |
| | 3 | 1 | - | 3 | - | - | 2 | - | - | | | |
| | 8300 Kg | | | 6900 Kg | | | 4600 Kg | | | | | |



S52 4T



Mecanismos- Mechanisms- Antriebe- Mécanismes- Meccanismi

(SF19)25 Hp (18,5 Kw) 3V
H.B.G. 84 S/R Ø10mm

| | | | | | | | | | |
|---|---|-------|---------|------|------|---------|------|------|------|
|  |  | m/min | 8 | 31 | 62 | 4 | 16 | 31 | |
| | | 240 m | Kg | 2500 | 2500 | 1500 | 4000 | 4000 | 2600 |
| | | | Kw | 18,5 | 18,5 | 18,5 | 18,5 | 18,5 | 18,5 |
|  | | m/min | 30 / 60 | | | 30 / 60 | | | |
| | | Kw | 3 | | | 3 | | | |
|  | | r.p.m | 0,3 | 0,6 | 0,9 | 0,3 | 0,6 | 0,9 | |
| | | Nm | 2x55 | | | 2x55 | | | |
|  | | m/min | 20 | | | 20 | | | |
| | | Kw | 2 x 2,2 | | | 2 x 2,2 | | | |





* (SF19INV)25 Hp (18,5 Kw) INV
H.B.G. 94 S/R Ø10mm



| | | | | | | | | | |
|---|---|-------|----|------|------|------|------|------|------|
|  |  | m/min | 8 | 31 | 62 | 4 | 16 | 31 | |
| | | 265 m | Kg | 2500 | 2500 | 1500 | 4000 | 4000 | 2600 |
| | | | Kw | 18,5 | 18,5 | 18,5 | 18,5 | 18,5 | 18,5 |

| | | | | |
|---|--|----------------|------------------|--------------------------------------|
|  2000/14/CEE 2005/88/CEE |  2006/95/CEE | 400 V 50 Hz | * 460 V 60 Hz | * 25 Hp (18,5 Kw) 31 Kw / 120 kVA |
| | | | | 15 Hp (11,5Kw) 3V 24 Kw / 90 kVA |

| | | | |
|---|------------------------|------------------------|------------------------|
|  | 25 m | 50 m | 100 m |
| 15 Hp (11,5 KW) 3V | 4 x 16 mm ² | 4 x 16 mm ² | 4 x 25 mm ² |
| 25 Hp (18,5 KW) 3V | 4 x 25 mm ² | 4 x 25 mm ² | 4 x 25 mm ² |
| 25 Hp (18,5 KW) INV | 4 x 25 mm ² | 4 x 25 mm ² | 4 x 25 mm ² |

* 15 Hp (11,5Kw) 3V
H.B.G. 84 S/R Ø10mm

| | | | | | | |
|---|---|-------|---------|------|------|------|
|  |  | m/min | 8 | 29 | 58 | |
| | | 240 m | Kg | 2500 | 2500 | 1000 |
| | | | Kw | 11,5 | 11,5 | 11,5 |
|  | | m/min | 30 / 60 | | | |
| | | Kw | 3 | | | |
|  | | r.p.m | 0,3 | 0,6 | 0,9 | |
| | | Nm | 2 x 55 | | | |
|  | | m/min | 20 | | | |
| | | Kw | 2 x 2,2 | | | |

| | | | | |
|---|--|----------------|------------------|----------------------|
|  2000/14/CEE 2005/88/CEE |  2006/95/CEE | 400 V 50 Hz | * 460 V 60 Hz | * 15 Hp (11.5 Kw) 3V |
| | | | | 24 KW / 90 kVA |

| | | | |
|---|------------------------|------------------------|------------------------|
|  | 25 m | 50 m | 100 m |
| 15 Hp (11.5 KW) 3V | 4 x 16 mm ² | 4 x 16 mm ² | 4 x 25 mm ² |

- * Opcional / Optional / Opzionale /
- Elevación / Hoisting / Heben / Levage / Sollevamento
- Distribución / Trolleying / Katzfahren / Distribution / Distribuzione
- Orientación / Slewing / Schwenken / Orientation / Rotazione
- Traslacion / Travelling / Schienenfahren / Translation / Traslazione

FEM 1005-C25 / EN 14439- Mástil / Reacciones- Masts / Reactions- Mast / Eckdrücke- Mat / Réactions- Torre / Réazioni

- C: TORRE S/TL 36-41-46-40-45 1.20 M39/M39
- D: TORRE S/TL 50-52 1.20 M39/M39 8/8
- E: TORRE TL 55 1.20 M39/M39 8/8
- J: CAMPANA S17 10m 1.2/1.7 M39/M45 8/8
- K: TORRE S17 1.70 M45 8/8
- L: TORRE S17 1.70 M45 16/8
- M: TORRE S17 1.70 M45 16/16
- N: CAMPANA S21-S17 8/8 M45
- O: TORRE S21 8/8 M45
- P: TORRE S21 16/8 M45
- X: CAMPANA C2322/21 16 /16 M45L /M45
- T: TORRE S2322 16 /16 M45L
- U: TORRE S2326 16 /16 M52 /M45L
- Z: TORRE S2326 24 /16 M52

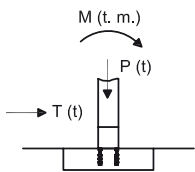
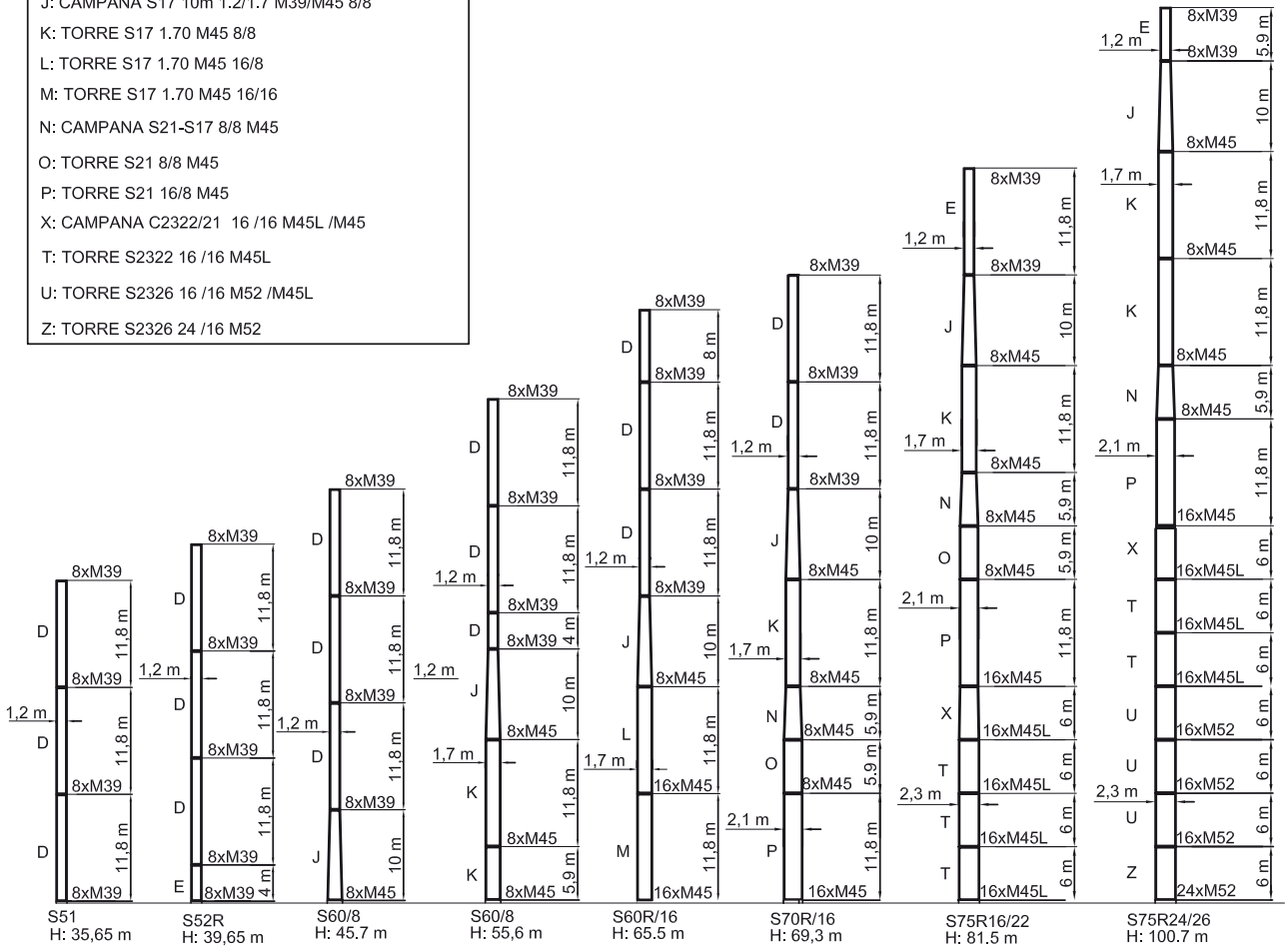

| | | | | | | | |
|---------|-------|------|-------|------|------|-------|------|
| H (m) | 23.8 | 35.6 | 39.7 | 45.7 | 49.7 | 53.7 | 57.5 |
| M (T-m) | 106.4 | 160 | 197.4 | 262 | 318 | 355.2 | 409 |
| T (t) | 4.9 | 6.5 | 7.1 | 8.2 | 8.9 | 9.4 | 10.1 |
| P (t) | 19 | 21.5 | 22.6 | 25.1 | 26.8 | 27.7 | 29.8 |

| | | | | | | | |
|---------|------|------|------|------|------|------|-------|
| H (m) | 99.4 | 91.6 | 80.9 | 75.2 | 69.3 | 65.2 | 63.4 |
| M (T-m) | 1350 | 1170 | 830 | 694 | 594 | 520 | 493.2 |
| T (t) | 23 | 20.5 | 16.5 | 15 | 13.5 | 12.4 | 11.1 |
| P (t) | 76 | 69 | 54.4 | 50 | 45 | 39.7 | 33.2 |

S52 4T

FEM 1005-C25 / EN 14439- Bloque lastre de base- Base ballast block- Grundballastblöcke - Bloc de lest de base- Blocco di zavorra alla base

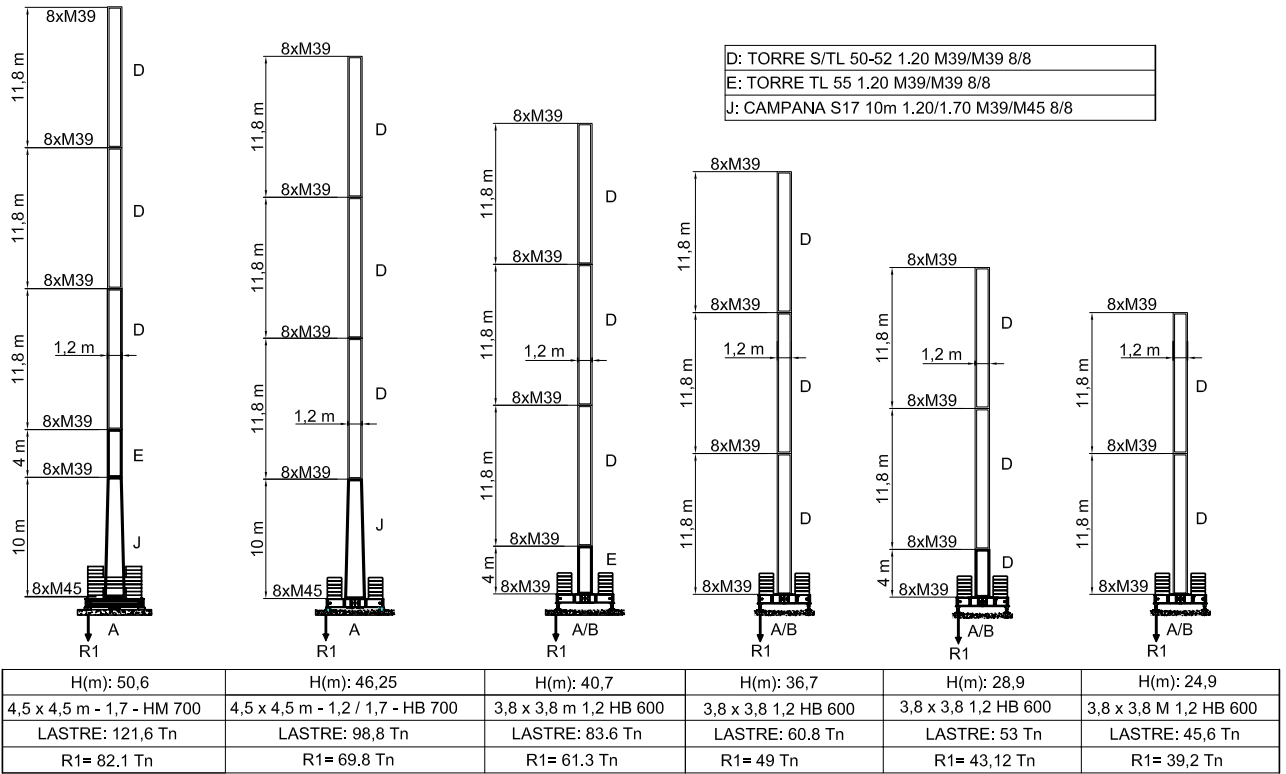

Proceso de trepado- External climbing- Kletterkrane- Telescopable- Sopralzo idraulico

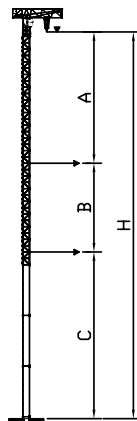



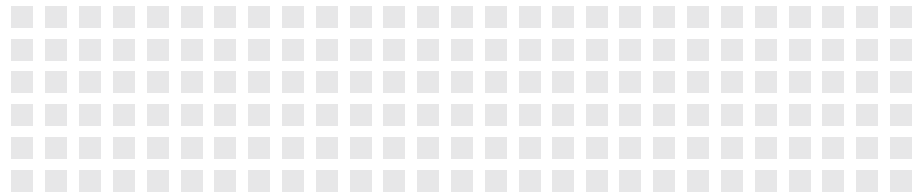

| | |
|--------|----------------------|
| | MONOBLOCK SM110/3,85 |
| | MTS |
| A max. | 29 |
| B max. | 19 |
| C max. | 31 |
| H max. | ① |

①

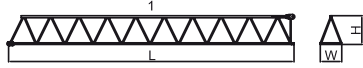
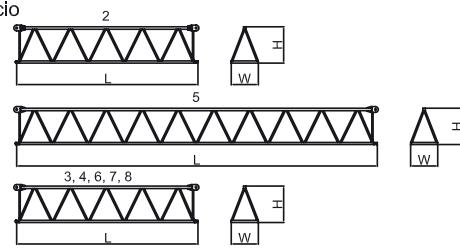
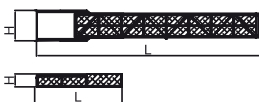
Consultarnos-Consultateci-Consult us-Nous consulter-Auf anfrage

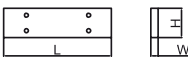

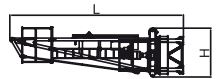
| | L(m) | W(m) | H(m) | Peso(Kg) | |
|--|---------------------------------|--|--|--|---------------------|
| Pluma tramo primero / First jib section/Ausleger-Anlenkstück / Pied de flèche /Settore articolato di braccio  | 11,85 | 1,04 | 1,3 | 982 | |
| Elemento intermedio de pluma /Intermediate jib section / Ausleger-Zwischenstück Élément interm. de flèche / Spezzone di braccio  | 2 3 4 5 6 7 8 | 5,94 5,94 5,94 11,74 5,14 3,64 2 | 0,95 0,95 0,95 0,95 0,95 0,95 0,95 | 1,32 475 450 915 328 225 142 | |
| Contrapluma / Counter-jib/Gegenausleger / Contre-flèche/Controbraccio  | 11,5 4,05 | 0,26 0,33 | 1,48 0,58 | 1480 96 | |
| Bloque de contrapeso / Counterweight blocks/Gegengewichtsblöcke / Bloc de contrepoids Blocco di contrappeso  | A B C | 2,94 2,94 1,70 | 0,30 0,18 0,18 | 1,25 1,25 1,25 | 2300 1400 850 |
| Bloque lastre de base / Base ballast block/Grundballastblöcke / Bloc de lest de base Blocco di zavorra alla base  | 4,4 | 1,2 | 0,3 | 3800 | |
| Gancho y Carro / Hook and Trolley/Lasthaken - Laufkatze / Crochet - Chariot Gancio e Carrello  | 0,75 0,96 | 0,12 1,10 | 1,40 0,62 | 164 118 | |
| Cabeza de torre / Tower head/Turmspitze / Porte - flèche/Testa di torre  | 6,5 | 1,8 | 1,7 | 3504 | |

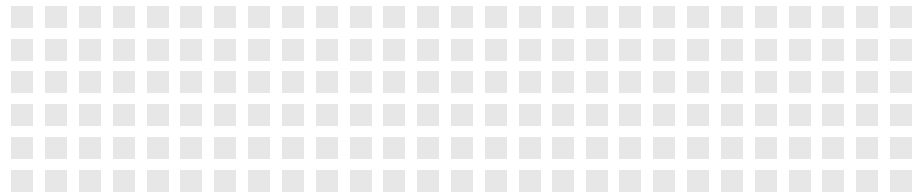

S52 4T

Elemento de torre / Tower section/Turmstück / Elément de mât
Elemento di torre



L(m) W(m) H(m) Peso(Kg)

| | | | | |
|---|------|------|------|------|
| D | 11,8 | 1,2 | 1,38 | 3017 |
| D | 8 | 1,2 | 1,38 | 2075 |
| D | 5,9 | 1,2 | 1,38 | 1560 |
| D | 4 | 1,2 | 1,38 | 1100 |
| E | 11,8 | 1,2 | 1,38 | 3782 |
| E | 8,0 | 1,2 | 1,38 | 2654 |
| E | 5,9 | 1,2 | 1,38 | 2090 |
| E | 4,0 | 1,2 | 1,38 | 1527 |
| J | 10 | 1,85 | 1,38 | 3520 |
| K | 11,8 | 1,85 | 1,85 | 4600 |
| K | 5,9 | 1,85 | 1,85 | 2472 |
| K | 3 | 1,85 | 1,85 | 1425 |
| L | 11,8 | 1,85 | 1,85 | 5520 |
| M | 11,8 | 1,85 | 1,85 | 5670 |
| N | 5,9 | 2,27 | 2,27 | 3500 |
| O | 11,8 | 2,27 | 2,27 | 5044 |
| O | 5,9 | 2,27 | 2,27 | 2640 |
| O | 3 | 2,27 | 2,27 | 1545 |
| P | 11,8 | 2,27 | 2,27 | 5700 |
| Q | 11,8 | 2,27 | 2,27 | 5900 |
| X | 6 | 2,27 | 2,29 | 4000 |
| T | 6 | 2,27 | 2,29 | 4300 |
| U | 6 | 2,31 | 2,34 | 5910 |
| Z | 6 | 2,61 | 2,34 | 5980 |

Elemento de empotre / Foundation anchor / Fundamentanker / Pieds de scellement /
El annegare

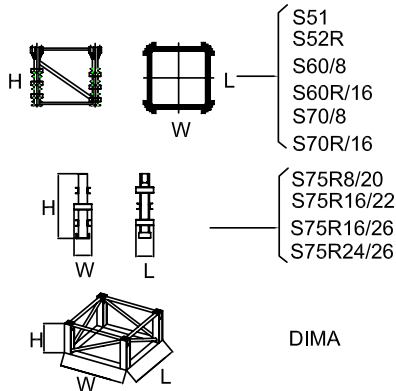





| | | | | |
|-----------|------|------|------|------|
| S51 | 1,2 | 1,38 | 1,42 | 496 |
| S52R | 1,2 | 1,38 | 1,42 | 594 |
| S60/8 | 1,85 | 1,85 | 1,6 | 956 |
| S60R/16 | 1,85 | 1,85 | 1,6 | 1108 |
| S70/8 | 2,28 | 2,28 | 1,6 | 1122 |
| S70R/16 | 2,28 | 2,28 | 1,6 | 1274 |
| S75R8/20 | 0,35 | 0,35 | 1,6 | 1200 |
| S75R16/22 | 0,50 | 0,50 | 2 | 2840 |
| S75R16/26 | 0,50 | 0,50 | 2,4 | 3160 |
| S75R24/26 | 0,50 | 0,50 | 2,4 | 3400 |
| DIMA | 2,31 | 2,34 | 0,8 | 1650 |

Cabina y soporte / Cabin and platform / Kabine und wartungs / Cabine et support /
Cabina e supporto

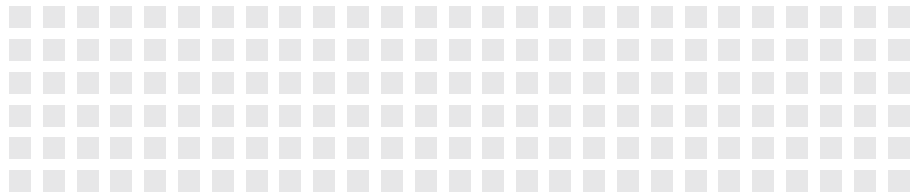

| | | | |
|------|------|------|-----|
| 3,00 | 1,15 | 2,35 | 558 |
|------|------|------|-----|

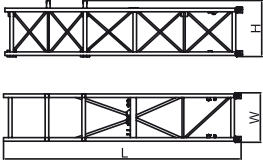
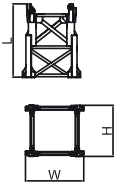
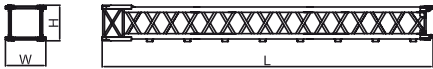
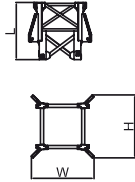

| | L(m) | W(m) | H(m) | Peso(Kg) |
|---|------|------|-------|----------|
| Tramo trepador SM110 / Climbing tower section / Turmstück/ Mâture télescopable / / Elemento di torre monolitico  | 4.09 | 1,17 | 1,22 | 1420 |
| Jaula de telescopaje SM110 / Climbing cage / Hydraulikbühne/Cage de télescope / Gabbia di montaggio  | 8.1 | 1,7 | 1,92 | 3840 |
| Tramo de transición SM110-1.2/1.09 / Climbing connection frame / Turmstück Elément de transition / Telaio di raccordo a spinta  | 1,74 | 1,38 | 1,21 | 811 |
| Tramo de transición SM110-1.2/1.09 / Climbing connection frame / Turmstück Elément de transition / Telaio di raccordo a spinta  | 11.2 | 1,38 | 1,21 | 4260 |
| Tramo de enlace a cabina SM110-1.09/1.2 / Climbing cage connection frame / Turmstück Elément de connection pour la cage de télescope / Telaio di raccordo a spinta  | 1,5 | 1,65 | 1,65 | 875 |
| Viga principal base 3.8 HB600 / Main base beam/Hauptträger für fundamentkreuz Poutre de châssis de base/Trave principale della base  | 5,72 | 0,67 | 0,65 | 1570 |
| Semiviga secundaria base 3.8 HB600 / Half base beam/Halbräger für fundamentkreuz Semipoutre de châssis de base /Semitrave secundaria della base  | 2,77 | 0,45 | 0,665 | 800 |

DECLINAMOS TODA RESPONSABILIDAD DERIVADA DE LA INFORMACION PROPORCIONADA.

This information is supplied without liability.

Sämtliche Angaben erfolgen ohne Gewähr.

Ces renseignements sont sans garantie.

Le indicazioni contenute si intendono salvo errori ed omissioni.

ESPECIFICACIONES SUJETAS A MODIFICACIONES SIN PREVIO AVISO.

Specifications subject to modification without notice.

Obiges kann ohne berstaendigung geaendert werden.

Specifications susceptibles de modification sans avis préalable.

Specifiche suscettibili di variazioni senza preavviso.